

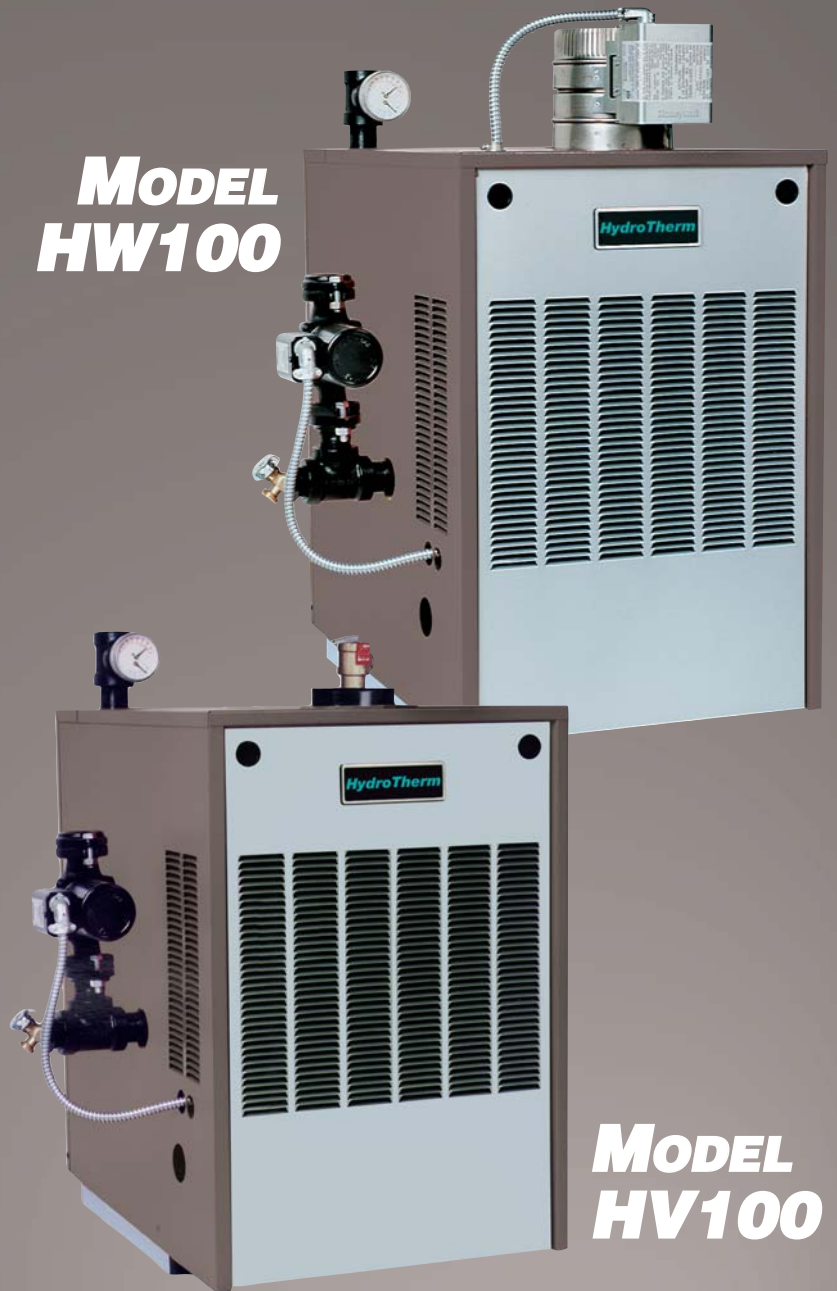

## **GAS FIRED RESIDENTIAL BOILER WITH POWER VENT OPTION**

**MODEL  
HW100**



**MODEL  
HV100**

**by HydroTherm**



# HW100 AND HV100

## Designed With You In Mind

*The HW/HV100 gas-fired residential boilers combines application flexibility with high efficiency. Whether vented through a conventional chimney or through the wall, the HW/HV100 offers efficient, dependable service.*



## Cast Iron Sections Built To Last



The cast iron sections of the Hydrotherm HW/HV100 Series boiler have thicker walls and up to 30% more cast iron than competitive boilers. Extra-deep 2 3/4" sections increase the boiler's water content and total water surface. Benefits of these superior design features include better heat transfer and heat retention,

and an Annual Fuel Utilization Efficiency exceeding 84%. The deeper section design also helps reduce mineral buildup and corrosion.\*

### Low Silhouette

The HW/HV100 features an internal draft diverter that allows venting directly off the top of the already low silhouette. Simple connection of the flue pipe to the boiler collar completes the HW/HV100's high-efficiency venting system and ensures safe discharge of all products of combustion.

### Built and Backed for a Lifetime

Without question, cast iron boiler construction delivers superior durability and longer life. Every HW/HV100 cast iron section is pressure tested at 2½ times the working pressure, then retested upon assembly at 1½ times the working pressure. The finished boiler is also factory test-fired to eliminate the expense and inconvenience of callbacks. We back our commitment to your complete satisfaction with a lifetime warranty.\*

\*See warranty statement for complete details



## STANDARD EQUIPMENT

Completely packaged and wired gas hot water boiler.

- Cast iron sections
- Deluxe insulated metal jacket with removable front panel
- Burner base with high temperature insulation board and burner tubes
- Integral flue collector and draft diverter
- A.S.M.E. pressure relief valve
- Taco "007" circulator
- Temperature pressure gauge
- Brass hose end drain valve
- Constant pilot ignition system
- Automatic vent damper (HW)
- Safety spill switch (HW)
- Flame rollout safety switch
- High limit and control center
- Pressure Switch (HV)
- Inducer (HV)
- Constant Standing Pilot (HW)
- HSI Pilot (HV)

## OPTIONAL EQUIPMENT

- Intermittent "spark" ignition system (HW)
- Propane gas
- Noncombustible floor pan for use on combustible floors

## Service Made Simple

All components are completely enclosed within the HW/HV100 cabinet. Yet, when it's time to service the boiler, nothing could be easier. Simply lift the front panel up and off for ready access to all wiring and controls. The layout allows easy visualization and adjustment.



## Power Vent

The HV100 gas-fired boiler offers economical operation with a highly efficient power vented draft system. Unlike conventional boilers which must heat up the chimney to create a natural draft, the HV100 utilizes an induced draft blower to vent flue gases safely up the chimney. Because of the integral blower design, venting is also permitted directly through an outside wall, making it ideal for installations in which no chimney is available, such as converting electrically heated homes, apartments and condominiums. The HV100 can also be commonly vented with a conventional gas water heater into a traditional masonry or Type B chimney.

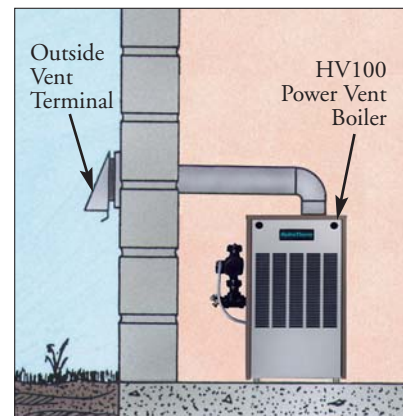
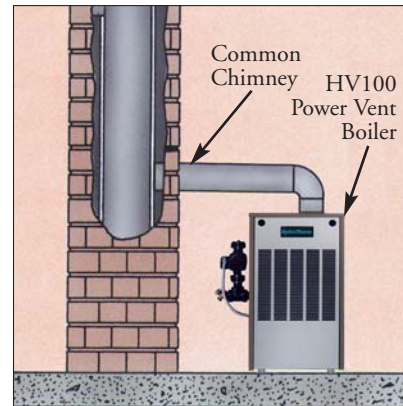

# HW/HV100

## GAS FIRED RESIDENTIAL BOILER

CSA Certified heating capacity ratings from 50,000 – 200,000 MBH

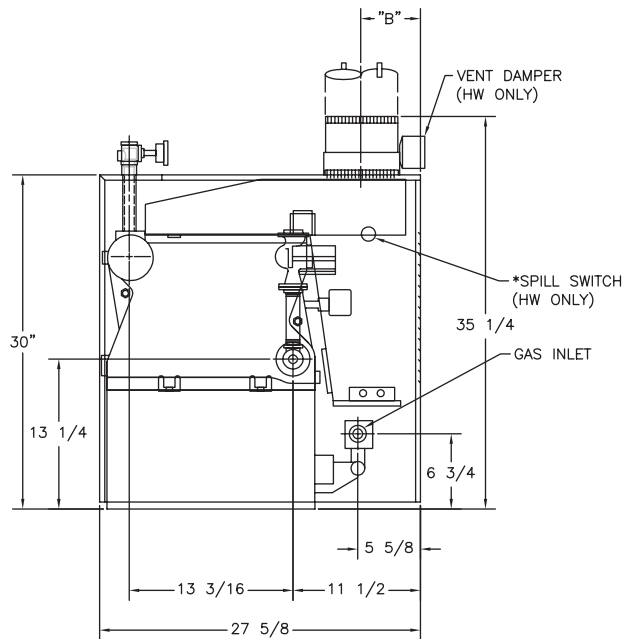

SIDE VIEW

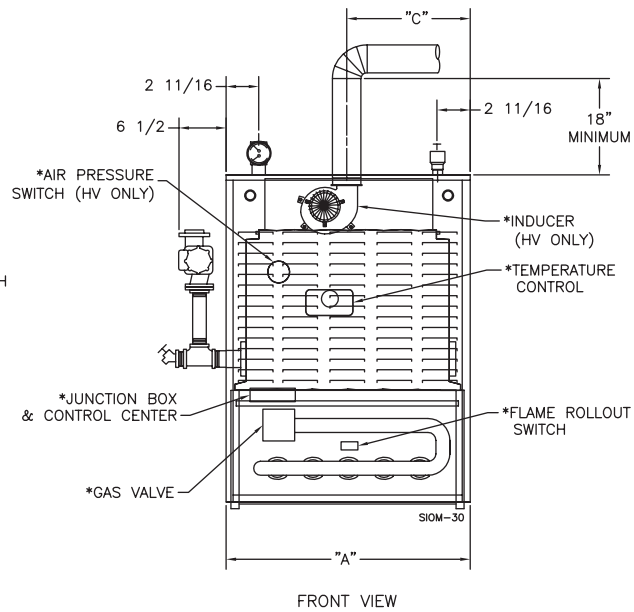

FRONT VIEW

\*BEHIND FRONT PANEL

Note: For closet, alcove or combustible floor installations, add 3" to the height dimensions.

### HW100 Specifications

Boiler Model Number	Natural/L.P.			A.F.U.E. <sup>①</sup>	Vent Damper	Dimensions (Inches)	
	AGA Input MBH	D.O.E. Htg. Cap. MBH	Net I=B=R Ratings MBH	Spark Ignition		A	B
HW100-3	50.0	42	36	84.3%	5"	10 <sup>7</sup> / <sub>8</sub> "	4 <sup>1</sup> / <sub>2</sub> "
HW100-4	75.0	63	55	84.0%	5"	13 <sup>3</sup> / <sub>8</sub> "	4 <sup>1</sup> / <sub>2</sub> "
HW100-5	100.0	83	72	83.5%	6"	16 <sup>3</sup> / <sub>8</sub> "	5"
HW100-6	125.0	104	90	83.2%	6"	19 <sup>1</sup> / <sub>8</sub> "	5"
HW100-7	150.0	125	109	83.3%	7"	21 <sup>7</sup> / <sub>8</sub> "	5 <sup>1</sup> / <sub>2</sub> "
HW100-8	175.0	146	127	83.2%	7"	24 <sup>3</sup> / <sub>8</sub> "	5 <sup>1</sup> / <sub>2</sub> "
HW100-9	200.0	167	145	83.2%	8"	27 <sup>3</sup> / <sub>8</sub> "	6"

① With Stack Damper

### HV100 Specifications

Boiler Model Number	Natural/L.P.			A.F.U.E.	Dimensions (Inches)			
	AGA Input MBH	D.O.E. Htg. Cap. MBH	Net I=B=R Ratings MBH	Spark Ignition	A	C	Vent Connector Diameter (Chimney or Vertical B Vent)	Vent Connector (Horizontal or Vertical Single Wall Sheet Metal)
HV100-3	50.0	42	37	83.8%	10 <sup>7</sup> / <sub>8</sub> "	2 <sup>7</sup> / <sub>8</sub> "	4"	4"
HV100-4	75.0	63	55	84.3%	13 <sup>3</sup> / <sub>8</sub> "	3 <sup>3</sup> / <sub>8</sub> "	4"	4"
HV100-5	100.0	84	73	84.1%	16 <sup>3</sup> / <sub>8</sub> "	5 <sup>3</sup> / <sub>8</sub> "	4"	4"
HV100-6	125.0	104	90	83.4%	19 <sup>1</sup> / <sub>8</sub> "	5 <sup>3</sup> / <sub>8</sub> "	5"	4"
HV100-7	150.0	125	109	83.5%	21 <sup>7</sup> / <sub>8</sub> "	5 <sup>3</sup> / <sub>8</sub> "	5"	4"

## Advanced Thermal Hydronics

260 North Elm Street, Westfield, MA 01085  
 (413) 564-5545 • FAX: (413) 562-8437  
 7555 Tranmere Drive, Mississauga, Ont. L5S 1L4  
 (905) 672-2991 • FAX: (905) 672-2883

www.mestek.com  
 A MESTEK COMPANY

In the interest of product improvement, we reserve the right to make changes without notice.

